

Edge Counter Kits

The **Edge** modular counter system presents a unique opportunity to provide clients with full modular capabilities. **Edge** counters are constructed without joiners. They are connected frame-to-frame unless joiners are required for their configuration. All counter panels are single sided laminate except where the insides are visible. All posts are made of anodized aluminum and all trusses are raw aluminum. The **Edge** allows a counter that is personalized to a client's requirements to obtain the traditional look of a customized unit, but with all of the advantages that come with a modular system. The unique features of this system are: Tool-free assembly • Seamless finish • Free design & re-design service • Versatility • Extensive accessory range • Free setup instructions • Lifetime warranty on materials & workmanship • No hidden fees. *Note: listed prices are for hardware only. Graphics content (layout, printing & lamination) is extra. Transit cases are extra.*

Isometric View

Plan View

E-CTK-2

Square Counter
w/Lockable Door &
1 Internal Shelf

Dimensions-
Panels: 37"H x 23"W x 17"D
Counter Top: 27"W x 21"D
Weight: 51.5 lbs

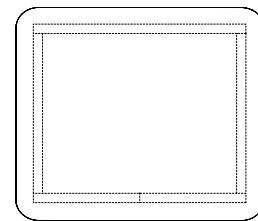
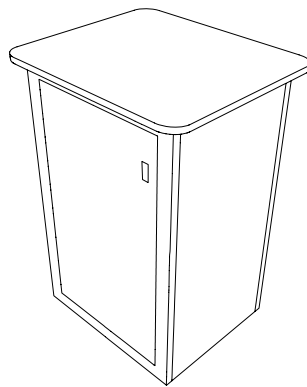

E-CTK-3

Rectangular Counter
w/Lockable Doors &
1 Internal Shelf

Dimensions-
Panels: 37"H x 34.5"W x 17"D
Counter Top: 38.5"W x 21"D
Weight: 65 lbs

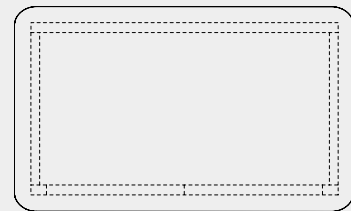
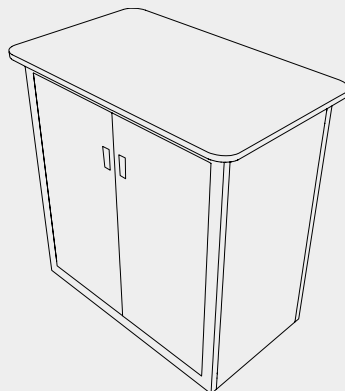

E-CTK-4

Rectangular Counter
w/Lockable Doors &
1 Internal Shelf

Dimensions-
Panels: 37"H x 46"W x 17"D
Counter Top: 48"W x 25"D
Weight: 82.7 lbs

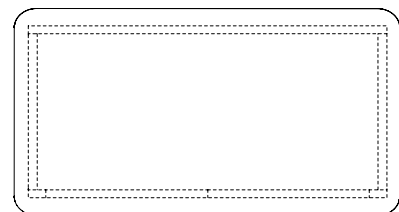
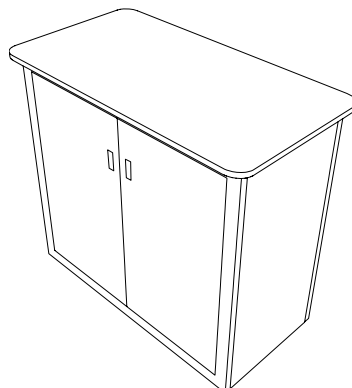

Isometric View

Plan View

E-CTK-5

Oval Counter
w/Lockable Doors
& 1 Internal Shelf

Dimensions-
Panels: 37"H x 64"W x 17"D
Counter Top: 66"W x 30"D
Weight: 94 lbs

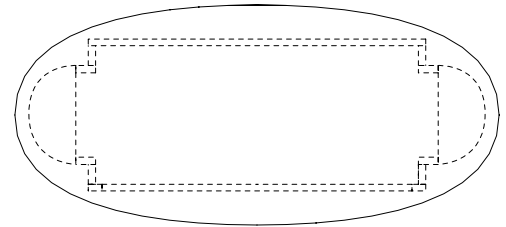
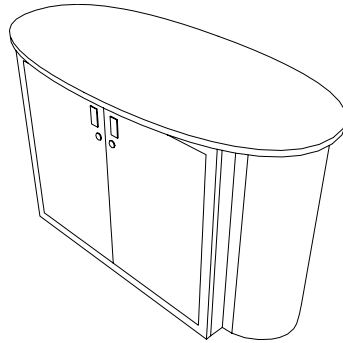

E-CTK-6

Semi-Circular Counter
w/Lockable Doors

Dimensions-
Panels: 37"H x 69"W x 23"D
Counter Top: 71"W x 26"D
Weight: 93 lbs

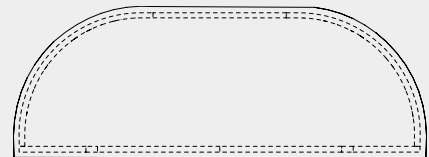
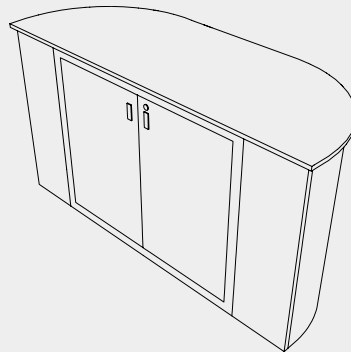

E-CTK-7

Semi-Circular Counter
w/Lockable Doors

Dimensions-
Panels: 37"H x 46"W x 23"D
Counter Top: 48"W x 26"D
Weight: 53.5 lbs

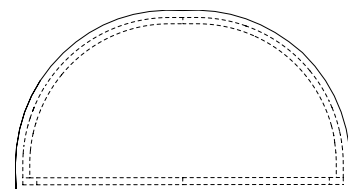
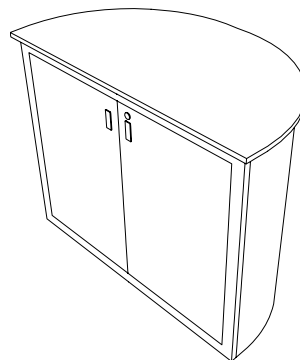

E-CTK-8

Kidney Counter
w/Lockable Doors

Dimensions-
Panels: 37"H x 52"W x 22"D
Counter Top: 58"W x 26"D
Weight: 75.5 lbs

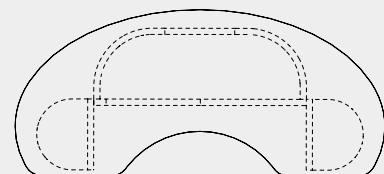
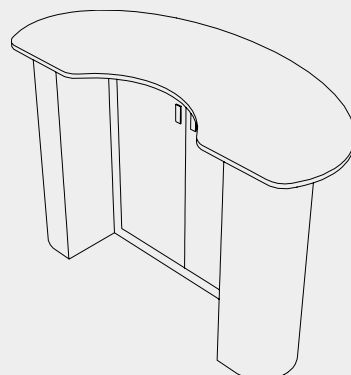

Isometric View

Plan View

E-CTK-9

Kidney Counter w/Side Post, Lockable Doors & 1 Internal Shelf

Dimensions-
 Panels: 37"H x 55"W x 19"D
 Counter Top: 60"W x 30"D
 Pole: 96"H
 Weight: 82 lbs

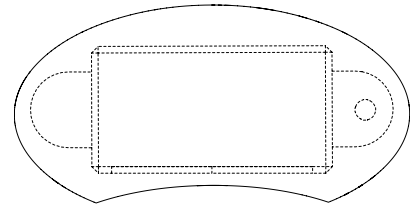
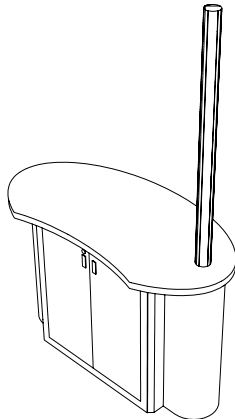

E-CTK-10

Kidney Counter w/ Extended Top, Side Truss Support & 2 Tilted Open Shelves

Dimensions-
 Panels: 37"H x 23"W x 17"D
 Counter Top: 60"W x 26"D
 Weight: 72.4 lbs

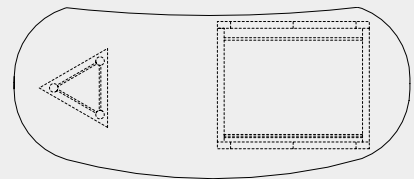

E-CTK-11

Semi-Oval Counter w/Extended Top, Side Post, Lockable Doors & 1 Internal Shelf

Dimensions-
 Panels: 37"H x 40"W x 17"D
 Counter Top: 52"W x 32"D
 Pole: 96"H
 Weight: 68.8 lbs

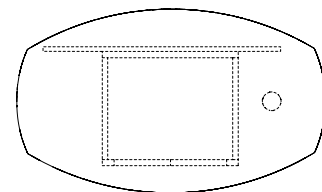
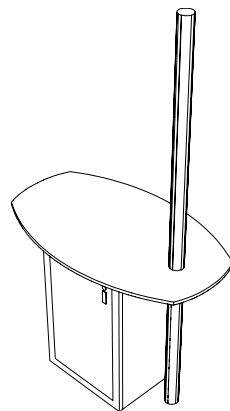

E-CTK-12

Kidney Counter w/Extended Top, Side Wing Supports, Lockable Door & 1 Internal Shelf

Dimensions-
 Panels: 37"H x 44"W x 19"D
 Counter Top: 48"W x 24"D
 Weight: 63.5 lbs

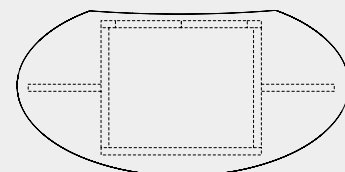
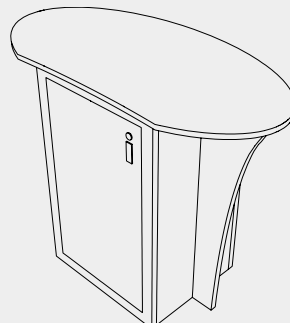

Isometric View

Plan View

E-CTK-13

Oval Counter w/Side Post,
Lockable Door & 1
Internal Shelf

Dimensions-
Panels: 37"H x 44"W x 19"D
Counter Top: 48"W x 24"D
Pole: 96"H
Weight: 74 lbs

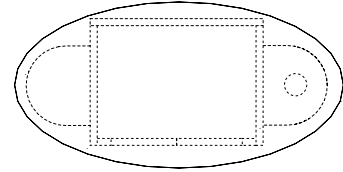
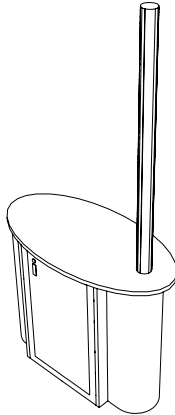

E-CTK-14

Oval Kiosk Counter
w/Extended Top, Side
Truss & Lockable Door

Dimensions-
Panels: 37"H x 23"W x 23"D
Counter Top: 45"W x 32"D
Truss: 85"H
Weight: 62 lbs

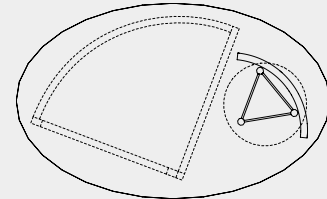
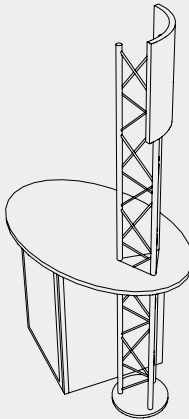

E-CTK-15

Semi-oval Counter w/
Extended Top, Side Truss
Support, Lockable Door
& Upper Opening w/Shelf

Dimensions-
Panels: 37"H x 34.5"W x 19"D
Counter Top: 56"W x 28"D
Weight: 74 lbs

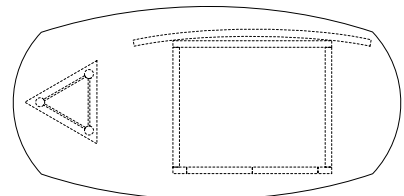

E-CTK-16

Rectangular Counter
w/Rounded Sides

Dimensions-
Panels: 37"H x 44"W x 18"D
Counter Top: 47"W x 22"D
Weight: 63 lbs

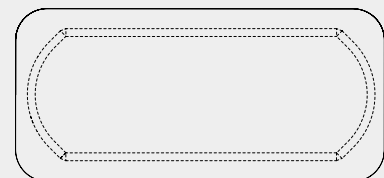
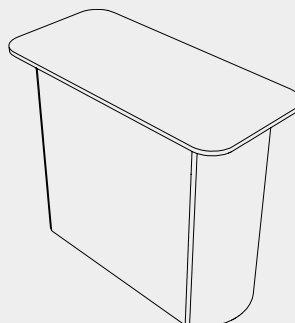

Isometric View

Plan View

E-CTK-17

Rectangular Counter
w/Side Truss Supports,
Lockable Doors & 1
Internal Shelf

Dimensions-
Panels: 37"H x 46"W x 19"D
Counter Top: 50"W x 24"D
Weight: 93 lbs

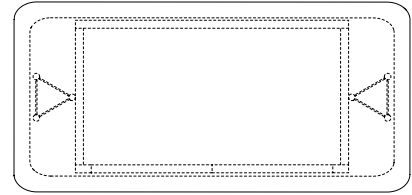
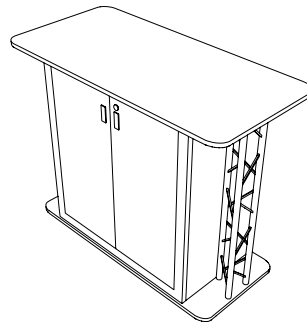

E-CTK-18

Square Counter
w/Rear Truss Support,
Lockable Door &
1 Internal Shelf

Dimensions-
Panels: 37"H x 23"W x 19"D
Counter Top: 25"W x 26"D
Truss: 85"H
Weight: 73 lbs

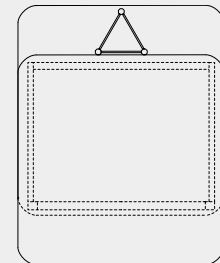
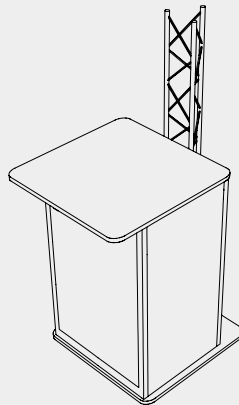

E-CTK-19

Semi-Oval Counter
w/2 Tilted Open Shelves
& Lockable Door

Dimensions-
Panels: 37"H x 25"W x 17"D
Counter Top: 36"W x 29"D
Weight: 60 lbs

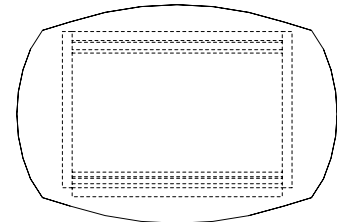
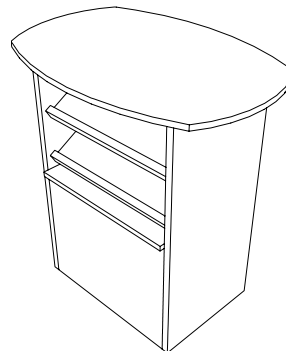

E-CTK-20

Semi-Oval Counter
w/2 Tilted Open Shelves
& Lockable Door

Dimensions-
Panels: 37"H x 34.5"W x 17"D
Counter Top: 43"W x 25"D
Weight: 75 lbs

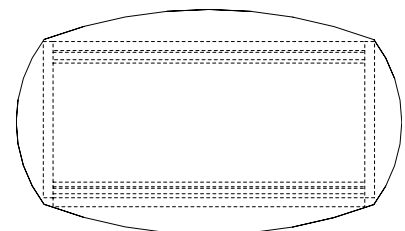

Isometric View

Plan View

E-CTK-21

Semi-Oval Kiosk Counter
w/Rear Middle Post &
Lockable Door

Dimensions-
Panels: 93"H x 34.5"W x 26"D
Counter Top: 35"W x 28"D
Weight: 100 lbs

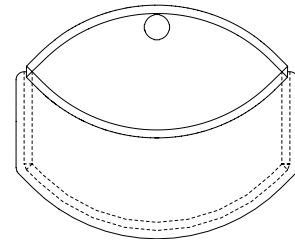
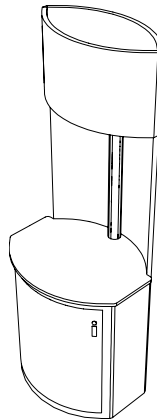

E-CTK-22

Rectangular Counter
w/Side Banner Post,
Lockable Doors & 1
Internal Shelf (Note:
Graphic Banner is extra)

Dimensions-
Panels: 40"H x 23"W x 19"D
Counter Top: 28"W x 24"D
Post: 76"H
Weight: 63 lbs

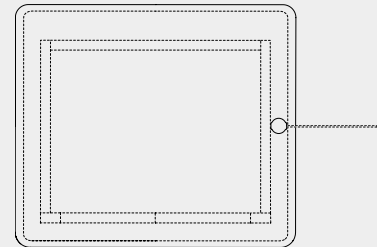
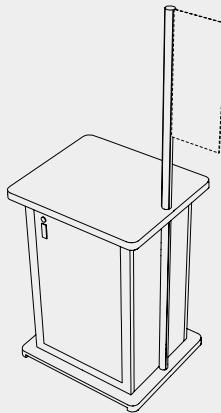

E-CTK-23

Square Counter w/Side
Banner Post, Lockable
Door & 1 Internal Shelf
(Note: Graphic Banner
is extra)

Dimensions-
Panels: 42"H x 23"W x 25"D
Counter Top: 28"W x 28"D
Post: 76"H
Weight: 72.5 lbs

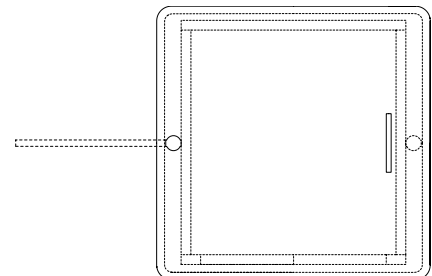
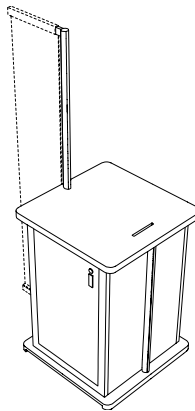

E-CTK-24

Rectangular Counter
w/ Lockable Door & 1
Internal Shelf

Dimensions-
Panels: 37"H x 23"W x 20"D
Counter Top: 38"W x 29.5"D
Weight: 68.5 lbs

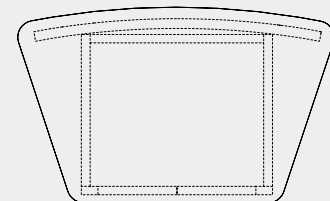
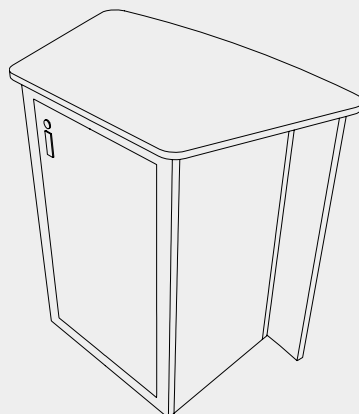

Edge Counter Kits

Isometric View

Plan View

E-CTK-25

Kidney Counter w/Side
Truss Supports, Lockable
Doors & 1 Internal Shelf

Dimensions-

Panels: 37"H x 34.5"W x 19"D

Counter Top: 60"W x 30"D

Weight: 84 lbs

