

# TABLE TOP & FLOOR SCREENS

Partition with Purpose.

Our new series of table top and floor screens make it effortless to arrange a great looking exhibit or dividing wall. Choose from our standard collection or customize to your specifications. Panels may be single or double sided. All units fold together flat with features such as lightweight construction and simplicity. These displays present themselves as serious portable contenders.



## GRAPHIC PANEL OPTIONS:

Attach graphic panel on front of the extrusion with magnetic tape.

In-fill panel (max. thickness 1/4" / 6 mm) goes into the track of the extrusion.

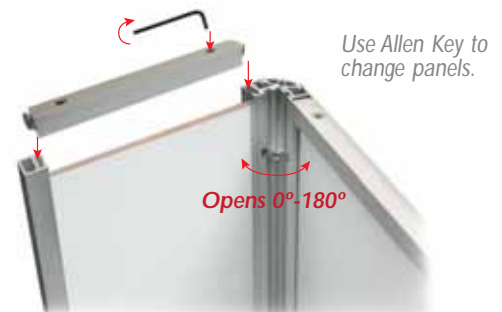
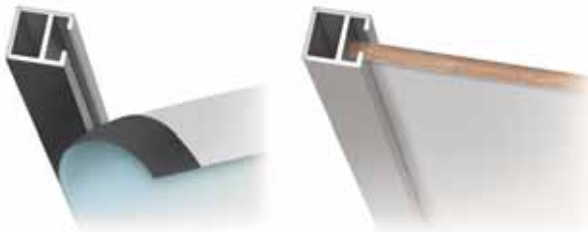

**SPECIFICATIONS**



Complete aluminum construction built in our HingeLine System for easy folding. Panels not included. Packed in carton box.

**52020** Table Top, 3-folded,  
36" (91.4 cm) H

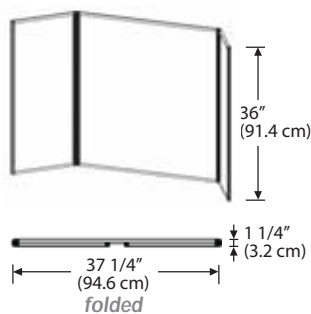

Configuration Examples:  
0° - 180° hinge action



**52025** Floor Screen, 3-folded,  
72" (182.9 cm) H

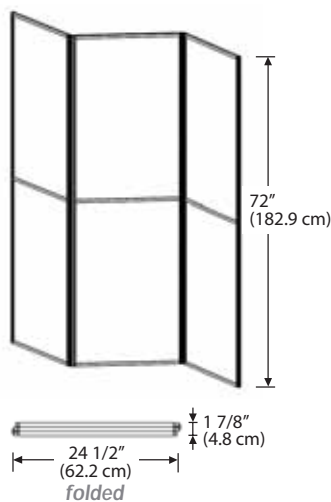

Configuration Examples:  
0° - 180° hinge action



**52030** Floor Screen, 4-folded  
72" (182.9 cm) H

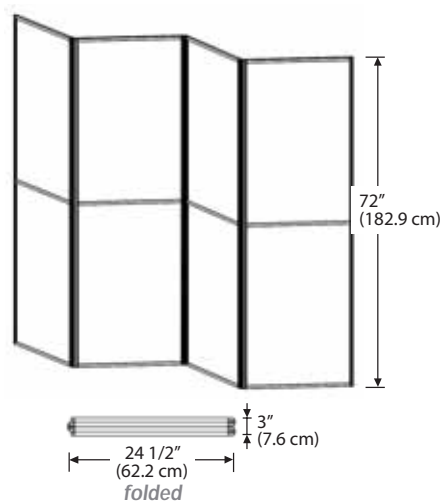

Configuration Examples:  
0° - 180° hinge action

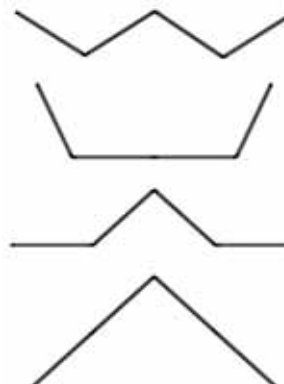

**CUSTOMIZE SIZE, CONFIGURATION & PANEL MATERIALS:**



For special attention, 2-panel unit combined with high Podium (pg. 40-41).



Semi-transparent panels to separate without blocking the view.



Back-drop on exhibits combined with sign panel and HingeCounter (pg. 58-59).



Play with effects, use wood, metal, perforated materials, graphic prints, etc.